

**SPA MICROPROCESSOR COMBINED TACHO&SPEEDO/GAUGE  
INSTALLATION AND OPERATING MANUAL**

PAGE 2 ....INSTRUMENT FEATURES

PAGE 3 ....OPERATING INSTRUCTIONS

PAGE 3 ....MENU SYSTEM

PAGE 11....INSTALLATION DIAGRAMS

PAGE 15....INSTALLATION NOTES

PAGE 17....SPECIFICATIONS

## **INSTRUMENT FEATURES**

BUILT IN LED GEAR INDICATOR

THREE COLOUR NEEDLE FOR GEAR SHIFT

FAST AND SMOOTH STEPPER MOTOR DRIVEN NEEDLE

MICROPROCESSOR ACCURACY

BUILT IN DIGITAL TACHOMETER

BUILT IN SPEEDOMETER/GAUGE\*

TIMER FOR 0-60 ETC

STANDING QUARTER TIMER

INTERNAL 3 STAGE SHIFT LAMP

EXTERNAL SHIFT LAMPS (OPTIONAL)

BACKLIT SCALE AND DISPLAY

'LIGHTS ON' WIRE FOR DAY AND NIGHT BRIGHTNESS

MAXIMUM RECALLS

TRIP MILEOMETER (SELECTABLE)\*

\*ACCORDING TO MODEL OPTION

## OPERATING INSTRUCTIONS:-

When the SPA tachometer is first switched you will see SPA and version information displayed on the LCD display, and you will see the needle drive back to the Shift leds and then forward to the zero mark. The LCD display will now read speed or gauge data according to model option and the tachometer will now register engine RPM.

Pressing the red button after this will either recall any stored maximum speed and RPM (shown by <sup>REC</sup> symbol on the LCD display) on the tachometer, or on the speedo/tacho version, this can also be configured to recall the trip mileometer. The red button can also be configured so that it can access the menu system or reset maximums when held down for more than 4 seconds.

The SPA Microprocessor tachometer is factory set to standard defaults, but may be easily be adjusted to your requirements using a menu system that will be explained further on.

If the supply voltage to the instrument drops to below 8.00 Volts, a small battery symbol will display on the left of the LCD display indicating that battery volts are low. The tachometer will still function normally at this voltage, but if the voltage drops down below 5.5 volts, the instrument will reset itself.

## MENU SYSTEM:-

To access the menu, hold down the red button and then switch on the instrument. On the display you will see **tSt** on the LCD display, now release the button. If you now press the red button momentarily again you will see it goto to the next menu option, keep doing this to familiarise yourself with them. The sequence of displays and there meaning is shown below:-

**tSt** = Used for factory testing

**tot** = **total** distance recall recorded on odometer (Speedo version)

**SEt** = **SET** the demo mode on or off.

**bon** = **backlight on** or, **b--** = **backlight off**.

**brd** = **brightness day**, sets the daytime brightness off the backlight.

**brn** = **brightness night**, sets the nighttime brightness off the backlight.

**rCP** = **ReCall Peaks**. Recalls stored maximum rpm and speed (or gauge according to model)

**rtP** = **reset Peaks**, IE reset stored maximums to zero.

Speedo version:-

**St4** = routine for measuring **St**anding quarter time.

**SSP** = set **St**art **SP**eed for the acceleration timer.

**FSP** = set **Fin**ish **SP**eed for the acceleration timer.

**ACC** = routine for measuring **ACC**eleration time.

Pressure/Boost version:-

**Uni** = Set **Units** for pressure readout. **Psi, bAr, CM2**

**ALA** = Set **AL**Arm point for low pressure (over pressure on boost version)

**oFP** = Zero **oF**fset for **p**ressure

Temperature version:-

**dEg** = Set **dEg**rees for temperature readout.

**tYP** = Set the **tYPe** of temperature sensor used. **tEM**, **tHi**, **tLo**  
**ALA** = Set **ALAr**m point for high temperature

Volts version:-

**ALA** = Set **ALAr**m point for low voltage

All Versions:-

**CyL** = set the number of engine **CyL**inders routine.  
**SF1** = set the RPM **ShiFt** point one (green led).  
**SF2** = set the RPM **ShiFt** point two (yellow led).  
**SF3** = set the RPM **ShiFt** point three (red led).  
**nS2** = set the RPM **nee**dle **Shi**ft point two (pink needle).  
**nS3** = set the RPM **nee**dle **Shi**ft point three (red needle)  
**FLA** = set the shifts lights to **FLA**sh on shift point 3  
**nFL** = set the **nee**dle to **FLA**sh on needle shift point 3  
**Fto** = set the flash timeout time  
**nCb** = **nee**dle **Co**lour **bl**ue or, **nCr** = **nee**dle **Co**lour **re**d  
**vLo** = **vol**ts **Lo**w or, **vhi** = **vol**ts **hi**gh

Speedo version:-

**tr** = set **tr**igger points routine.  
**CAL** = set **CAL**ibration to tyre circumference routine.  
**rEA** = set **REA**dout to KMH, MPH or RPM indicated by "KPH", "MPH" or neither on the bottom right of the LCD display.

Gear indicator version:-

**gEA** = set number of gears.  
**LEA** = enter learn gear mode.  
**rAt** = view or modify gear ratio's.

All Versions:-

**SFU** = **Sw**itch **FU**ction. This sets the press and press/hold function of the red switch.  
**Eng** = This routine is for engineering access only.  
**rEt** = Exit the menu system and **rEt**urn to normal operation.

The display then scrolls back around to **tSt**.. To activate any option or routine, press and hold down the red button, the display will change after 2 seconds. A more detailed breakdown of each menu option is detailed on this and the following pages.

NOTE: For menus that require multiple choices like **SEt** and **SFU**, you will need to click to goto the next menu item afterward in order to store the new selection.

All versions:-

**tSt** This is used by SPA during production. If you really want to see what it does, Press and hold down the red button. After 2 seconds the LCD lights up all segments and the LED's come on dim. To return to the menu, click the button.

**Speedo version:-**

**tot** (total distance recall):- Press and hold down the red button, after 2 seconds the highest

part (thousands) of the current distance will be displayed. Press and hold down the red button again, after 2 seconds the lower part (units) of the current distance will be displayed (indicated by a decimal point to the left of the 3 digits). The distance will be in miles or KM according to the current readout selected. To return to menu at any point momentarily press the red button and you will return to the menu.

#### **All models:-**

**SEt** = **SEt** the demo mode on or off. When set on, the needle will ramp up and down repeatedly and the shift lights and needle colour will change. Peak recall is a fake and will return to normal when demo mode is off. The flash options can be set in the menu system to see what they look like, but the shift points are fixed in this mode.

**bon** (backlight on/off):- Press and hold down the red button, after 2 seconds the display changes to the desired option. Normally this is set to ON unless you need to reduce battery consumption.

**brd** = **b**rightness **d**aytime, set the daytime brightness off backlight.

Press and hold down the red button, after 2 seconds the display indicates the current daytime brightness level. To change the brightness, press the red button momentarily to increment it one at a time, or press and hold and the display will count up quickly. When the display reaches full brightness at **100**, it will scroll back round to **000** (dark). To exit the routine, release the button for more than 4 seconds and it will return to the menu.

**brn** = **b**rightness **n**ight, sets the nighttime brightness off the backlight as above. This is activated by the lights on wire so that you can choose either reduced brightness at night, or backlight with lights on only (by setting daytime brightness to zero).

**rCP** = **ReCall Peaks**. Recalls stored maximum rpm and speed (or gauge according to model)

**rtP** (reset peaks):- Press and hold down the red button, after 2 seconds the display shows ---. The stored maximums are now reset to zero. This should be done before any new maximums are to be stored.

Pressure/Boost version:-

**Uni** = Set **Units** for pressure readout for a standard SPA 16 bar sensor. **Psi, bAr, CM2** (Kg/Cm<sup>2</sup>)

Press and hold down the red button, after 2 seconds the display indicates the current selection. To change the option, press the red button momentarily to increment it one at a time. To exit the routine, release the button for more than 4 seconds and it will return to the menu.

**ALA** = Set **ALAr**m point for low pressure (over pressure on boost version)

Press and hold down the red button, after 2 seconds the display indicates the current selection. To change the number, press the red button momentarily to increment it one at a time, or press and hold, and the display will count up quickly. When the display reaches full scale it will scroll back round to **000** (000 = alarm inactive). To exit the routine, release the button for more than 4 seconds and it will return to the menu.

**oFP** = Zero **oFfset** for **p**ressure, use this to make the gauge read zero when the pressure sensor at zero pressure.

Press and hold down the red button, after 2 seconds the display changes to **rEA**. Release the button and the display now shows the voltage being read from the sensor. Ensure that the sensor is at zero pressure, then press and hold the red button for 2 secs until the display

changes to ---. Now wait until the display returns to **oFP**. To exit the routine, release the button for more than 4 seconds and it will return to the menu.

Temperature version:-

**dEg** = Set **dEg**rees for temperature readout.

Press and hold down the red button, after 2 seconds the display indicates the current selection. To change the option, press the red button momentarily to increment it one at a time. To exit the routine, release the button for more than 4 seconds and it will return to the menu.

**tYP** = Set the **tYPe** of temperature sensor used. **tEM** = standard brass **tEM**perature sensor, **tHi** = **thermocouple High** adapter box used, **tLo** = **thermocouple Low** adapter box used.

Press and hold down the red button, after 2 seconds the display indicates the current selection. To change the option, press the red button momentarily to increment it one at a time. To exit the routine, release the button for more than 4 seconds and it will return to the menu.

**ALA** = Set **ALAr**m point for high temperature

Press and hold down the red button, after 2 seconds the display indicates the current selection. To change the number, press the red button momentarily to increment it one at a time, or press and hold, and the display will count up quickly. When the display reaches full scale, it will scroll back round to **000** (000 = alarm inactive). To exit the routine, release the button for more than 4 seconds and it will return to the menu.

Volts version:-

**ALA** = Set **ALAr**m point for low voltage

Press and hold down the red button, after 2 seconds the display indicates the current selection. To change the number, press the red button momentarily to increment it one at a time, or press and hold, and the display will count up quickly. When the display reaches full scale it will scroll back round to **000** (000 = alarm inactive). To exit the routine, release the button for more than 4 seconds and it will return to the menu.

Speedo version:-

**St4** (standing quarter time):- This routine is used to display the current stored standing quarter time, terminal speed, terminal RPM, and to measure and store new times. To access this routine, press and hold down the red button, after 2 seconds the display will show the currently stored acceleration time. Press the button again momentarily to display terminal speed, and RPM, and press again to return to the **St4** menu.

To start a new standing quarter measurement, press and hold the button to display the current standing quarter time, then press and hold down the red button, after 2 seconds the display changes "---", release the button and normal road speed and RPM (with shift lights) will be now be displayed. Accelerate the car and as soon as the wheels begin moving, standing quarter timer will start, and your road speed will be displayed along with the "REC" symbol on the top right of the display. When you have travelled for a quarter of a mile, the "REC" symbol will go out, and your new standing quarter time will be displayed. To abort at any point in this routine, press the red button momentarily and the display will show the time from start (if any) to button press.

Press the button momentarily and you can view your terminal speed and RPM. Press again, and you will return to the **ST4** menu.

**SSP** (start speed):- Use this routine to enter the speed that you wish to start to measure the acceleration for. EG 0 for 0-60 MPH

Press and hold down the red button, after 2 seconds the display indicates the current acceleration speed the instrument is set to. To change the number, press the red button momentarily to increment it one at a time, or press and hold, and the display will count up quickly. When the display reaches **200** it will scroll back round to **000**. To exit the routine, release the button for more than 4 seconds and it will return to the menu.

**FSP** (finish speed):- Use this routine to enter the speed that you wish to finish measuring the acceleration for. EG 60 for 0-60 MPH

Press and hold down the red button, after 2 seconds the display indicates the current acceleration speed the instrument is set to. To change the number, press the red button momentarily to increment it one at a time, or press and hold, and the display will count up quickly. When the display reaches **200** it will scroll back round to **001**. To exit the routine, release the button for more than 4 seconds and it will return to the menu.

**ACC** (acceleration time):- This routine is used to display the current stored acceleration time, and to measure and store new acceleration times. To access this routine, press and hold down the red button, after 2 seconds the display will show the currently stored acceleration time. To start a new acceleration measurement, press and hold down the red button, after 2 seconds the display changes to "---" indicating it is ready. Accelerate the car and as soon as the wheels begin moving (for 0-60) or when the start speed has been reached, the speedo will start the acceleration timer, and your road speed will be displayed along with the "REC" symbol on the top right of the display. When you reach the programmed speed, the "REC" symbol will go out, and your new acceleration time will be displayed. To return to the menu at any point in this routine, press the red button momentarily and the display will change back to "ACC".

All versions:-

**CyL** (set cylinders):- Press and hold down the red button, after 2 seconds the current cylinders will be displayed. To change the number, press the red button momentarily to increment it one at a time, or press and hold down and the display will count up quickly. When the display reaches 32 it will scroll back round to 1. For certain types of ignition systems, that is ones that have more than one ignition coil per engine, it will be necessary to set the cylinders to a different number than the engine has. Also some systems give half the ignition pulses and so cylinders would be set to 2. Also most motorcycles use an ignition coil per pair of cylinders, so a 4 cylinder engine would need to be set to 2 on the tachometer since it will only see half the number of ignition pulses.

**SF1,2,3**(set shift rpm):- This routine is used to enter the shift points for the engine being used. When the engine RPM exceeds this shift point number, then the appropriate lamp will light. These are: -

**SF1** - green led

**SF2** - yellow led

**SF3** - red led (very bright)

If you wish you can also drive external shift lamps. (see installation notes for details) and also on a motorcycle you can use the lamps for warnings like oil and neutral too (see appendix).

Press and hold down the red button, after 2 seconds the current shift point will be displayed as x1000 RPM. To change the number, press the red button momentarily to count it up one hundred RPM at a time, or press and hold and the display will count up quickly. When the

display shows 39.90 it will scroll back round to 00.10 To exit the routine, release the button for more than 4 seconds and it will return to the menu, or switch off the instrument.

NOTE: In practice, you may find that when you look at your Maximum RPM recall, that you have over shot your highest shift point due human reaction time, so you may wish to decrease your shift point(s) to compensate for this and increase the efficiency of your gear shifting further. EG if you set the shift point to 7,900 but you Maximum RPM recall was 8,200 then set your shift point to 7,700 to compensate for your reaction time.

**nF2,3** (set needle shift colour rpm):- This routine is used to enter the needle colour shift points. When the engine RPM exceeds this needle shift point number, then the needle colour will change.

**nF2** – Pink needle

**nF3** - Red needle

Set these as above for the shift points.

**FLA** (set the shifts lights to flash on shift point 3) :- When the engine rpm exceeds shift point three, all the shift leds will flash if this option is set to on. The flashing will stop after the flash timeout time set below.

Press and hold down the red button. After 2 seconds, the display will show the current selection. Single click to change the current selection. To return to the menu, leave the button for 4 seconds.

**nFL** (set the **needle** to flash on needle shift point 3) :- When the engine rpm exceeds needle shift point three, the needle will flash if this option is set to on. The flashing will stop after the flash timeout time set below. Set as above.

**Fto** (set the flash timeout time) :- Set the time for the flashing of the shift led's and needle. After the time set here (seconds) the flashing will stop.

**nCb** (needle **Colour blue** or, **nCr needle Colour red**). Set this for the default needle colour. For a blue backlit dial this is normally set to blue, for a red backlit dial this is normally set to red. The needle shift colour will always be the reverse of the colour set here.

**vlo** (voltage low/high):- Press and hold down the red button, after 2 seconds the display changes to the desired option. Normally this is set to **vlo**, but if you are using magneto coil ignition you will have to select it to **vhi** to make the tacho input less sensitive.

Speedo version:-

**tr** (set trigger points):- Use this routine to enter the number of magnets (normally 1) that are to pass the speed sensor for one revolution of the wheel (or shaft).

Press and hold down the red button, after 2 seconds the display changes show the current number of trigger points the instrument is set to.

To change the number, press the red button momentarily to increment it one at a time, or press and hold, and the display will count up quickly. When the display reaches **100** it will scroll back round to **01** .To exit the routine, release the button for more than 4 seconds and it will return to the menu.

**CAL** (set calibration of tyre circumference):- This routine is used to enter the rolling circumference of the tyre being used. Since the whole accuracy of the speedo hinges in the accuracy of this data it is important to learn how to use it. It can also be used to "Trim" the speedo to take into account external errors and to cater for differential ratio's when measuring from prop shafts.

PLEASE NOTE: If the speedo is not calibrated and the sensor not set correctly, the speedo may record incorrect distance on the odometer. Correct operation is important since the odometer cannot be reset.

1) General calibration procedure:- Measure the exact circumference of the tyre at its centre. This circumference is now entered in two parts, set meters and set millimeters.

Press and hold down the red button, after 2 seconds the current circumference will be displayed in meters. To change the number, press the red button momentarily to increment it 0.1 at a time, or press and hold and the display will count up quickly. When the display reaches **4.0** it will scroll back round to **0.1**. When this has been set correctly, release the button. After 4 seconds the decimal point will shift to the left and display the remaining millimetres of circumference.

To change the number, press the red button momentarily to increment it one at a time, or press and hold and the display will count up quickly. When the display reaches **.999** it will roll over to **.000** and the meters will increase by **1**. To exit the routine, release the button for more than 4 seconds and it will return to the menu.

2) Special calibration:- If you require to trigger from a different sensor with for example 10 pulses per rev, then set the trigger points number to **10** in the set trigger points menu. If the sensor is running at wheel RPM then simply enter the tyre circumference as described above. However if the sensor is driven from a gearbox output (EG before the differential) then using a calculator, divide the circumference of the tyre by the ratio of the differential (or whatever the drive ratio between the sensor and the wheel is due to gears, chains etc), and enter this value as the circumference (See set calibration as described at the beginning of this section).

If you require to trim the accuracy of the speedo because for example the differential ratio is not accurately known, and you have determined that the speedo is reading say 2% high, then using a calculator, subtract 2% off the currently stored circumference value and enter this new figure as the circumference value (See set calibration as described at the beginning of this section). The speedo will then read 2% lower than previously.

**rEA** (set readout):- Use this option to change the readout to MPH, KMH or RPM. Press and hold down the red button, after 2 seconds the display changes to the desired option, as indicated by "KPH" or "MPH" symbols on the bottom right of the LCD display. When neither symbols are displayed, the LCD is displaying engine RPM.

**gEA** (gears). Set the number of gears (1-9) the vehicle has I.E. the top gear number.

**LEA** (Learn mode). Use this to enter gear learning mode. Press and hold down the red button, after 2 seconds the display show ---. Release the button and the gear 1 flashes softly. Engage first gear and drive off normally (more than 10 mph) accelerate fairly slowly. When the gear starts flashing 2, change to second gear etc. When the top gear has been learned the tachometer will restart and the gears will be displayed.

**rAt** (ratios). Use this to view or adjust gears ratios. Press and hold down the red button, after 2 seconds the display shows 1 for gear 1.

All versions:-

**SFU** Press and hold down the red button. After 2 seconds, the display will show the current selection for the switch function (what happens when you hold down the red button in normal gauge operation). These are in sequence

**rCP** (recall maximums only)

**rrP** (recall maximums and after 5 seconds reset maximums)

**rPm** (recall maximums and after 5 seconds access the menu)

**rCt** (recall trip only)

**rrt** (recall trip and after 5 seconds reset the trip)

**rtm** (recall trip and after 5 seconds access the menu).

Single click to change the current selection. To return to the menu, leave the button for 4 seconds.

**Eng** (engineering) This routine is for engineering access only and is code locked.

**rEt** (return):- Use this option to exit the menu system and restart the instrument for normal operation. Press and hold down the red button, after 2 seconds the display will go blank, when you release the button, the instrument will restart.

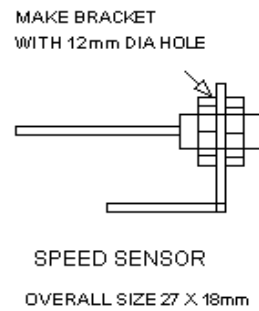
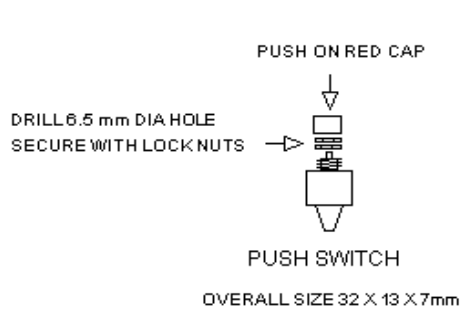
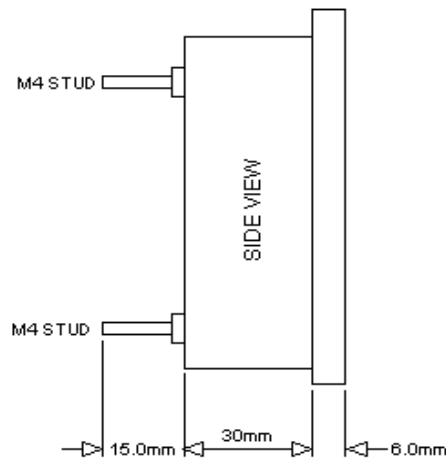
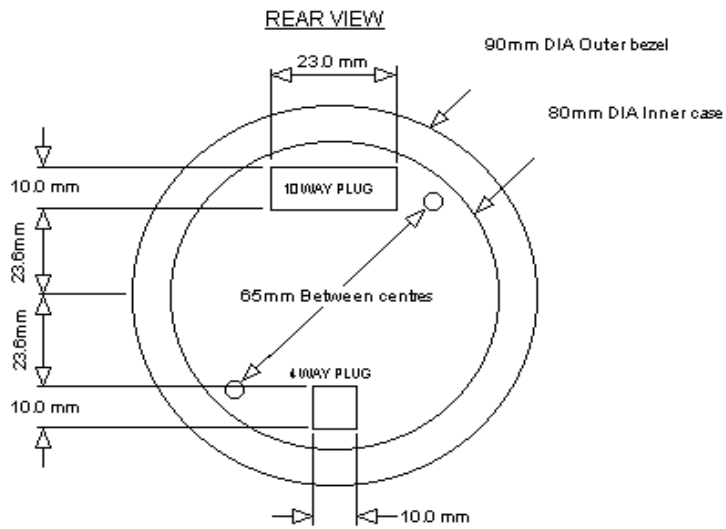

### TEMPERATURE SENSOR MOUNTING

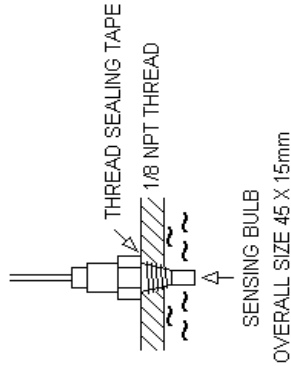

### PRESSURE SENSOR MOUNTING

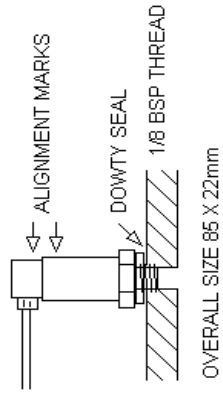

### TACHO OUTPUT CONNECTION (PREFERRED METHOD)

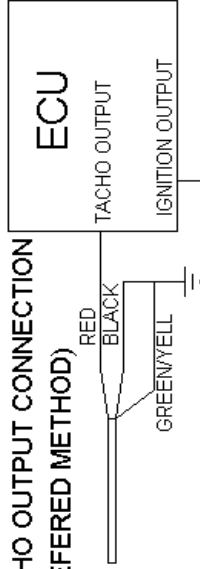

**OR**

### IGNITION COIL CONNECTION

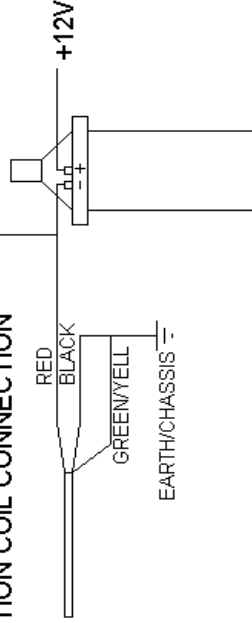

### IGNITION COIL

TITLE:	DATE:
Universal tachometer sensor guide.DSN	29/11/2000
BY: J.COTTIER	PAGE: 1/1
REV: 1.0	REV: 1/1

## SPEEDO SENSOR INSTALLATION GUIDE

### TYPICAL CAR INSTALLATION

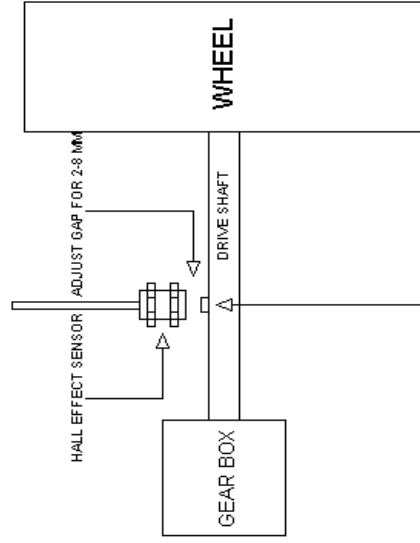

### TYPICAL MOTORCYCLE INSTALLATION

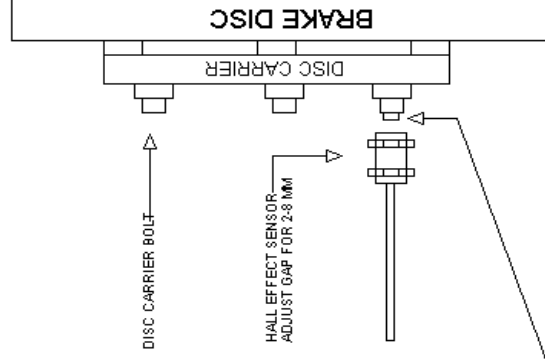

PLEASE NOTE THAT ONLY ONE MAGNET IS NOW NEEDED AND ONE IS SUPPLIED

A SUITABLE BRACKET WILL NEED TO BE MADE FOR MOUNTING THE HALL EFFECT SENSOR. THIS SHOULD BE MOUNTED ON A NON MOVING MEMBER.

DISC MAGNET  
GLUE WITH NORTH POLE  
FACING DOWN\* ON THE DRIVESHAFT  
USE EPOXY GLUE TO FIX  
EG ARALDITE OR PERMABOND.

\* MARKED BY DIMPLE OR RED PAINT

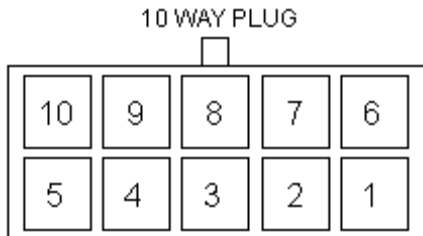

PIN NUMBER	FUNCTION	NOTE
5	GROUND (0V)	4
4	+12 VOLTS BATTERY	1
1	TACHO+	
6	TACHO -	
7	'LIGHTS ON' PIN	2
2	SWITCH (GROUND)	
3	SWITCH (SIGNAL)	3
9	+12 VOLT OUT	
10	SPEED SENSOR SIGNAL	5
8	SPEED SENSOR GROUND	

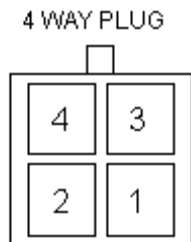

PIN NUMBER	FUNCTION	
1	+12 VOLTS BATTERY	6
2	EXTERNAL SHIFT LIGHT 1	7
4	EXTERNAL SHIFT LIGHT 2	7
3	EXTERNAL SHIFT LIGHT 3	7

- NOTE 1) 28V MAXIMUM SUPPLY
- NOTE 2) CONNECT TO VEHICLE LIGHTING +12 FEED
- NOTE 3) NORMALLY OPEN SWITCH
- NOTE 4) CONNECT DIRECT TO CHASSIS
- NOTE 5) 5V SIGNAL WITH 10K PULL UP
- NOTE 6) 500mA MAX LOAD
- NOTE 7) 100mA MAX LOAD

## **INSTALLATION, DO'S & DON'TS :-**

### **DO'S**

DO ensure that the front of the instrument and the exposed plug is protected if it is likely to get any water spray on it.

DO ensure that the speedo cable is not run next to the tacho cable or any power cable, try to run it next to the chassis.

### **DONT'S**

DO NOT allow cables to run through sharp edged apertures without protection.

DO NOT fix the cables next to or onto any surface likely to exceed 80 degrees Centigrade.

## **SPEEDO SENSOR INSTALLATION, DO'S & DON'TS :-**

### **DO'S**

DO ensure that the sensor is aligned with the end of the magnet when the suspension is under normal load (not jacked up).

## **APPENDIX**

### **TACHO IGNITION CONNECTION**

Please use a tacho output of the management, ECU or ignition box if this available. Most modern vehicles have tacho outputs. Some have weak outputs and do not like being loaded down to earth (SPA tacho puts on a 10K resistive load), in this case you need to connect the red wire to +12v batt, and the black wire to tacho output. If there is no tacho output available, you can connect the inductive pickup output from the crank sensor, also on Motorcycles you can usually pick up from one of the alternator phases, although these will require the cylinders settings to be changed to read correctly. For a crank sensor, set the cylinders to 2, for a motorcycle (crank driven) alternator set the cylinders to 12.

If you wish to connect to the ignition coil (see schematic) the SPA tacho is fully protected. It will connect to any coil including magneto's (select **vhi** in the menu for magneto) and is not damaged by reverse polarity. Connect black to chassis, and red to the ignition pulse side of the coil. **Do not** make any kind of connection to the HT leads or spark plugs, this voltage is highly destructive.

### **EXTERNAL SHIFT LAMPS**

If you wish to drive external shift lamps in addition to the internal ones, you can either use the SPA 3-stage led box optional extra, or if you wish you can use discrete leds. Leds must be of the 12v type and take no more than 100mA. If you need brighter lamps, you may drive a relay, but this must not take more than 100mA coil current, and **MUST** be fitted with a protection diode (EG 1N4001) across the relay coil.

### **SHIFT LAMPS AS WARNING LIGHTS**

If you wish to use the internal shift lamps as warning lights on a motorcycle, this can be done with any sensor that switched to earth (chassis). This usually means that oil pressure

and neutral indicator switch sensors can directly drive the shift lamps. EG red for oil pressure, green for neutral. The diagram on the following page shows how to do this.

You can either use the lamps as indicator lights and shift lamps (dual purpose), or if you want warning lights only, then set the shift points to a high value you engine cannot reach. In this case you still have the needle shift light for gear shifting.

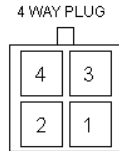

PIN NUMBER	FUNCTION	WIRE
1	+12 VOLTS BATTERY	RED
2	EXTERNAL SHIFT LIGHT 1 (GREEN)	GREEN
4	EXTERNAL SHIFT LIGHT 2 (YELLOW)	BLUE
3	EXTERNAL SHIFT LIGHT 3 (RED)	YELL

CONNECT TO EXISTING LOOM FOR WARNING LIGHTS

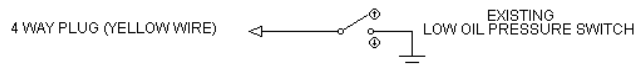

WHEN OIL PRESSURE IS LOW, THE SWITCH IS CLOSED AND LIGHTS THE RED SHIFT LED

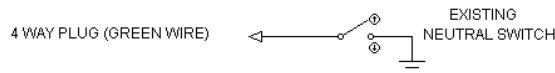

WHEN THE GEABOX IS IN NEUTRAL, THE SWITCH IS CLOSED AND LIGHTS THE GREEN SHIFT LED

SHIFT LIGHTS WILL STILL FUNCTION AS WELL IF DESIRED. TO INHIBIT SHIFT LIGHTS, SET TO A HIGH RPM VALUE

TITLE: External lights for oil and neutral warning.DSN	DATE: 18/10/2001
BY: J.COTTIER	REV: 1.0
	PAGE: 1/1

**SPECIFICATIONS:-**

INPUT VOLTAGE 8.0-26 VOLTS (working)  
CONSUMPTION 150 mA(max) @ 12 VOLTS  
FUSE 20mm glass 500mA Fast(F).

TACHO ACCURACY:-		0.05%
SPEEDO ACCURACY:-		0.05% TYPICAL
ACCELERATION TIMER	0.1 SEC	
STANDING QUARTER TIMER		0.1 SEC
DATA STORAGE:-		EEPROM
WEIGHT:-		180g INCLUDING FIXINGS
SIZE:-		90mm x 30mm DEEP
CUT OUT FOR MOUNTING		80mm
SPEEDO SENSOR FIXING DIA:-	10mm	
CABLE LENGTHS:- IGNITION LEAD	120"	
WHEEL SPEED SENSOR	120"	
POWER SUPPLY		12"
OPTIONAL EXTERNAL SHIFT LAMP(S)	40"	
ABSOLUTE MAXIMUM RATINGS:-		
INPUT VOLTAGE		28 VOLTS
INSTRUMENT TEMPERATURE		-40 - +80°C