

SPA DESIGN MICROPROCESSOR SPEEDO V2
INSTALLATION AND OPERATING MANUAL

CONTENTS

Page 2Instrument features.

Page 3Installation details.

Page 4Operating instructions.

Page 5Menu system.

Page 8....Specifications.

Page 9....Wiring schematic.

Page 10....Mounting data

INSTRUMENT FEATURES

Acceleration timer

Standing 1/4 mile timer

Built in odometer

Built in trip meter

Maximum speed recall

Adjustable backlit lcd display

Adjustable low battery warning

Programmable button function.

Readout selectable for mph or kmh

Calibrates to any tyre circumference

Instrument installation DO'S and DONT'S

DO not allow any stress on the mounting feet on the case.

DO ensure that the instrument is slightly below the drivers head for the clearest view.

DO ensure that the back of the instrument is protected from any water spray that may occur.

Cable installation, DO'S and DONT'S

DO ensure that the black screened cables do not run next to power cables, especially if they are ignition power cables. Ideally, run all screened cables next to the chassis (earth).

DO ensure that any exposed plugs that are likely to get water spray are protected with rubber boots.

DO NOT allow cables to run through sharp edged apertures without protection.

DO NOT fix the cables next to or onto any surface likely to exceed 80 degrees Centigrade.

Sensor installation DO'S and DON'TS

DO ensure that the sensor is pointing toward the south pole of the magnet (see page 12).
DO ensure that the sensor is aligned with the end of the magnet when the suspension is under normal load (car not jacked up).

The SPA Microprocessor speedo is set to standard default values, but these can be easily changed. These settings will stay in memory for many years when the power is off.

When switched on, the display will show the version number and then speed with an MPH or KMH symbol according to its setting.

When the button is pressed, a ^{REC} symbol shows the display is in recall mode for either stored maximums or tripmeter mileage (according to the button setting in the menu).

If the battery voltage falls below the low battery setting, then a battery symbol will flash. However the speedo will continue to work normally until around 8v when it will reset itself.

To access the speedo system menu, you can either hold down the red button while you switch on the power, or if the menu is configured for button access (factory default), press and hold down the red button for more than 5 seconds. On the display you will see tdP on the LCD display. Now release the button. If you now press the button momentarily again you will see the display change to the next menu option. Keep pressing the button to familiarize yourself with the menu items. A brief sequential view of options and their meaning is shown below:-

tdP= Test display (used in manufacture)

tot= Total distance recorded on odometer.

trP= Trip meter distance recall

rcP= Recall Peaks, IE recall stored maximum speed.

RtP= Reset Peak, IE reset stored maximum speed to zero.

rtt= Reset trip meter

bon= Backlight on or, b-- = Backlight off.

bri = Backlight brightness

Set= Set demo mode on/off

tr= set Trigger points routine.

CAL= set CALibration to tyre circumference routine.

St4= Standing quarter mile timer

SSP= set Start SPeed for the acceleration and mid range timer.

FSP= set Finish SPeed for the acceleration and mid range timer.

ACC= routine for displaying and measuring acceleration time.

Tst= TeST mode, used to set up and test the wheel sensor.

REA= set REAdout to KMH or MPH, indicated by _{KMH} or _{MPH} in the bottom right of the LCD display.

Lb= Low battery warning set point

SFU= Switch function, sets the function mode of the switch

Eng (Engineering)

rEt= return (exit) from menu system

The display then scrolls back round to **tdP**.

To activate any option or routine, press and hold down the red button, the display will change after 2 seconds. A more detailed breakdown of each menu option is detailed on the following pages.

tdP (Test display) used in manufacture, it activates all the segments of the LCD.

tot (Total distance):- Press and hold down the red button, after 2 seconds the highest part (thousands) of the current distance will be displayed. Press and hold down the red button again, after 2 seconds the lower part (units) of the current distance will be displayed (indicated by a decimal point to the left of the 3 digits). The distance will be in miles or KM according to the current readout selected. To return to menu at any point momentarily press the red button and the next menu item will appear.

trP (Recall trip):- If the button is programmed for recall peak mode, then you need this option to gain access to the tripmeter. Simply press and hold down the red button to view trip mileage, and release the button to return to the menu. Note: this can also be done by configuring the button function, see **SFU**

rcP (Recall peaks):- If the button is programmed for tripmeter mode, then you need this option to gain access to stored maximums. Simply press and hold down the red button to view stored maximum, and release the button to return to the menu. Note: this can also be done by configuring the button function, see **SFU**

rtP (Reset peaks):- Press and hold down the red button, after 2 seconds the display increments to the next menu item. The stored maximums are now reset to zero. This should be done before any new maximums are to be stored. Note: this can also be done by configuring the button function, see **SFU**

rtt (Reset trip):- Press and hold down the red button, after 2 seconds the display increments to the next menu item. The tripmeter is now reset to zero. Note: this can also be done by configuring the button function, see **SFU**

bon (Back light on/off):- Press and hold down the red button, after 2 seconds the display changes to the desired option.

bri (Brightness) Press and hold down the red button. After 2 seconds, the current brightness number will be displayed. Single click to increment (lighten) the LCD backlight, or press and hold again for 2 seconds and the brightness number will count up quickly. When the number reaches 15 it will go back to 0 (dark). To return to the menu, leave the button for 4 seconds.

Set (Set demo mode on/off):- Press and hold down the red button, after 2 seconds the display changes show the current setting. Single click to change to the desired option. To return to the menu, leave the button for 4 seconds.

tr (Set trigger points):- Use this routine to enter the number of points that are to pass the speed sensor for one revolution of the wheel (or shaft).

Press and hold down the red button, after 2 seconds the display changes to show the current number of trigger points the instrument is set to.

To change the number, press the red button momentarily to increment it one at a time, or press and hold, and the display will count up quickly. When the display reaches 100 it will scroll back round to 01. To return to the menu, leave the button for 4 seconds.

CAL (Set calibration of tyre circumference):- This routine is used to enter the rolling circumference of the tyre being used.

Since the whole accuracy of the speedo hinges in the accuracy of this data it is important to learn how to use it. It can also be used to "Trim" the speedo to take into account external errors and to cater for differential ratio's when measuring from prop shafts. PLEASE NOTE: If the speedo is not calibrated and the sensor not set correctly, the speedo may record incorrect distance on the odometer. Correct operation is important since the odometer cannot be reset.

1) General calibration procedure:- Measure the exact circumference of the tyre at its centre. This circumference is now entered in two parts, set metres and set millimetres.

Press and hold down the red button, after 2 seconds the current circumference will be displayed in metres. To change the number, press the red button momentarily only to increment it 0.1 at a time. When the display reaches 4.0 it will scroll back round to 0.1. When this has been set correctly, press and hold down the red button. The decimal point will now shift to the left and display the remaining millimetres of circumference.

To change the number, press the red button momentarily to increment it one at a time, or press and hold and the display will count up quickly. When the display reaches .099 it will scroll back round to .000. To return to the menu, leave the button for 4 seconds.

2) Special calibration:- If you require to trigger off a target with 4 magnets, then set the trigger points number to 4 in the SET TRIGGER POINTS menu.

If the target is running at wheel RPM then simply enter the tyre circumference as described above. However if the target is driving a differential, then using a calculator, divide the circumference of the tyre by the ratio of the differential, and enter this value as the circumference, as described at the beginning of this section.

If you require to trim the accuracy of the speedo because for example the differential ratio is not accurately known, and you have determined that the speedo is reading say 2% high, then using a calculator, subtract 2% off the currently stored circumference value and enter this new value as described in the at the beginning of this section. The speedo will then read 2% lower than previously.

St4 (Standing quarter time):- This routine is used to display the current stored standing quarter time, terminal speed, terminal RPM, and to measure and store new times. To access this routine, press and hold down the red button, after 2 seconds the display will show the currently stored acceleration time. Press the button again momentarily to display terminal speed, and RPM, and press again to return to the St4 menu.

To start a new standing quarter measurement, press and hold the button to display the current standing quarter time, then press and hold down the red button, after 2 seconds the display changes "---", release the button and normal road speed and RPM (with shift lights) will be now be displayed. Accelerate the car and as soon as the wheels begin moving, standing quarter timer will start, and your road speed will be displayed along with the "REC" symbol on the top right of the display. When you have travelled for a quarter of a mile, the "REC" symbol will go out, and your new standing quarter time will be displayed. To abort at any point in this routine, press the red button momentarily and the display will show the time from start (if any) to button press. Press the button momentarily and you can view your terminal speed and RPM. Press again, and you will return to the ST4 menu.

SSP (Start speed):- Use this routine to enter the start speed that you wish to measure the acceleration for. EG set to 0 for a 0-60 MPH timing. Press and hold down the red button, after 2 seconds the display indicates the current acceleration start speed the instrument is set to. To change the number, press the red button momentarily to increment it one at a time. When the display reaches 250 it will scroll back round to 000 . To return to the menu, leave the button for 4 seconds.

FSP (Finish speed):- Use this routine to enter the finish speed that you wish to measure the acceleration for. EG set to 60 for a 0-60 MPH timing. Press and hold down the red button, after 2 seconds the display indicates the current acceleration finish speed the instrument is set to. To change the number, press the red button momentarily to increment it one at a time. When the display reaches 250 it will scroll back round to 010. To return to the menu, leave the button for 4 seconds.

ACC (Acceleration time):- This routine is used to display the current stored acceleration time, and to measure and store new acceleration times. To access this routine, press and hold down the red button, after 2 seconds the display will show the currently stored acceleration time. To start a new acceleration measurement, press and hold down the red button, after 2 seconds the display changes to “---” indicating it is ready. Now accelerate the car. If you are measuring acceleration from a standing start, then as soon as the wheels begin moving, the speedo will start the acceleration timer, and your road speed will be displayed along with the “REC” symbol on the top right of the display. If you measuring a mid range time (EG 30-70 MPH), then you see your road speed indicated, but the “REC” symbol will not appear until your car has reached your start speed, at which point the timer is started. When your car has reached the programmed finish speed, the “REC” symbol will go out, and your new acceleration time will be displayed. To return to the menu at any point in this routine, press the red button momentarily and the display will change back to “ACC”.

tSt (Test mode):- This mode is used for setting up the mechanical position of the wheel speed sensor, to check that it is triggering properly. The display counts up every time a trigger pulse is received from the sensor so you can “see” it working. Also when the sensor is over magnet, the display shows ---

To use this mode, press and hold down the red button, after 2 seconds the display change to 000 (or ---). The speedo is now ready to receive trigger pulses. To exit this routine, press the red button and you will return to the menu.

rEA (Set readout):- Use this option to change the readout to MPH or KMH. Press and hold down the red button, after 2 seconds the display changes to the desired option, as indicated by “KPH” or “MPH” on the bottom right of the LCD display.

Lb (Low battery set point) Press and hold down the red button. After 2 seconds, the current low battery warning set point will be displayed. Single click to increment up, or press and hold again for 2 seconds and the set point will count up quickly. When the set point number reaches the 15.0 it will go back to 10.0. To return to the menu, leave the button for 4 seconds.

SFU (Switch function) Press and hold down the red button. After 2 seconds, the display will show the current selection for the switch function (what happens when you hold down the red button in normal gauge operation). These are in sequence

rCP (recall maximums only)

rrP (recall maximums and after 5 seconds reset maximums)

rPm (recall maximums and after 5 seconds access the menu)

rCt (recall trip only)

rrt (recall trip and after 5 seconds reset the trip)

rtm (recall trip and after 5 seconds access the menu).

Single click to change the current selection. To return to the menu, leave the button for 4 seconds.

Eng (engineering) This routine is for engineering access only and is code locked.

rEt Press and hold down the red button. After 2 seconds, the display will show --- . Release the button and the gauge will restart normally.

INPUT VOLTAGE	8.0-16 VOLTS (working)
CONSUMPTION	10 mA @ 12 VOLTS (42 mA BACKLIT)
ACCURACY:-	0.05% TYPICAL
ACCELERATION TIMER	0.1 SEC +/- 0.03%
CALIBRATION:-	DIGITAL
DATA STORAGE:-	EEPROM
WEIGHT:-	190g INCLUDING SENSORS,CABLES,ETC
SIZE:-	50mm x 30mm x 25mm DEEP PLUS 10mm EACH SIDE FOR MOUNTING FEET
SENSOR FIXING DIA:-	10mm
CABLE LENGTHS:-	WHEEL SPEED SENSOR - 120" POWER SUPPLY - 12" SWITCH LEAD - 24"
ABSOLUTE MAXIMUM RATINGS:-	
INPUT VOLTAGE	- 25 VOLTS
SPEED	999 MPH/KMH
ODOMETER	999,999 MILES/KM
INSTRUMENT TEMPERATURE	-20 to +70°C

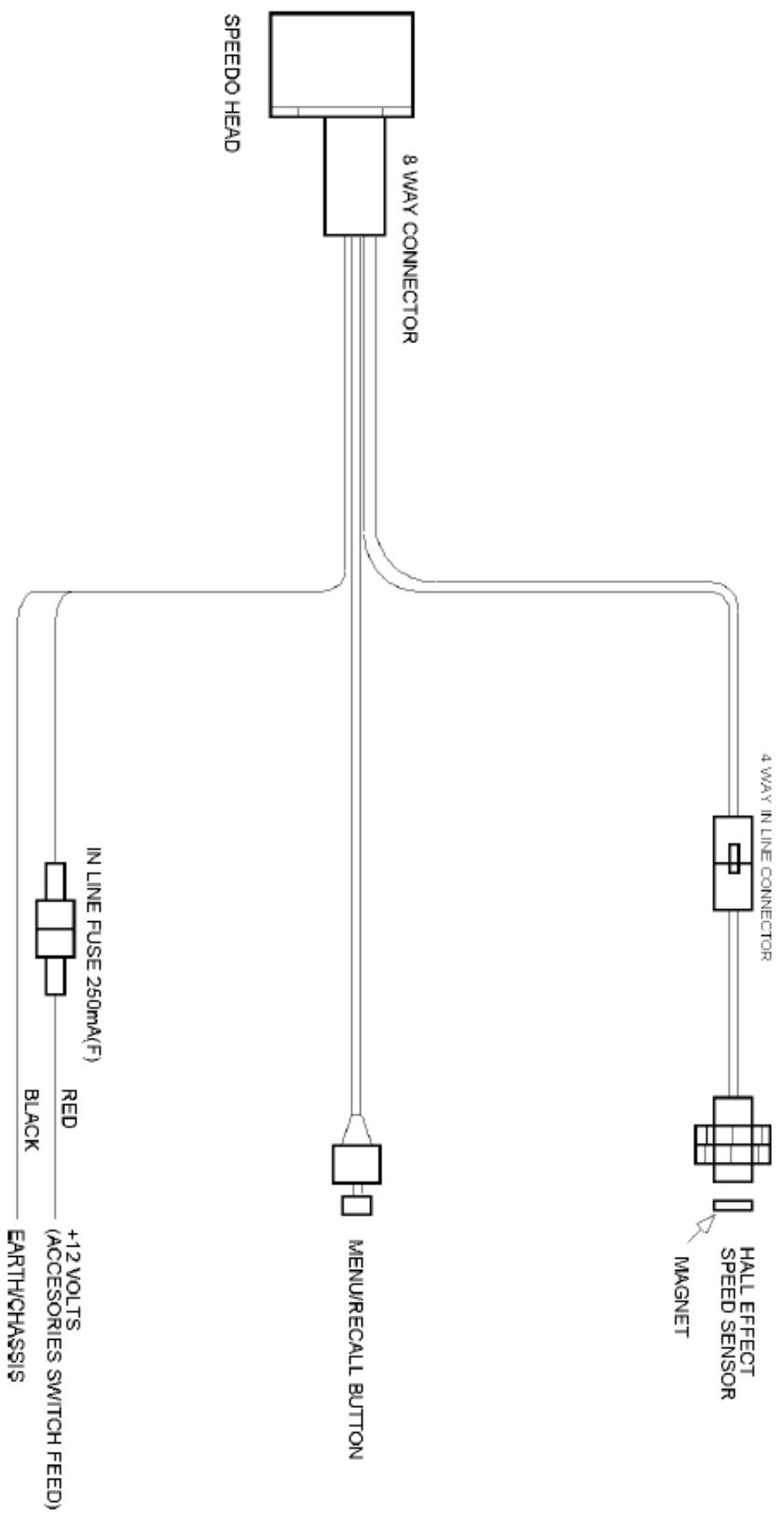

SPEEDO SENSOR INSTALLATION GUIDE

TYPICAL CAR INSTALLATION

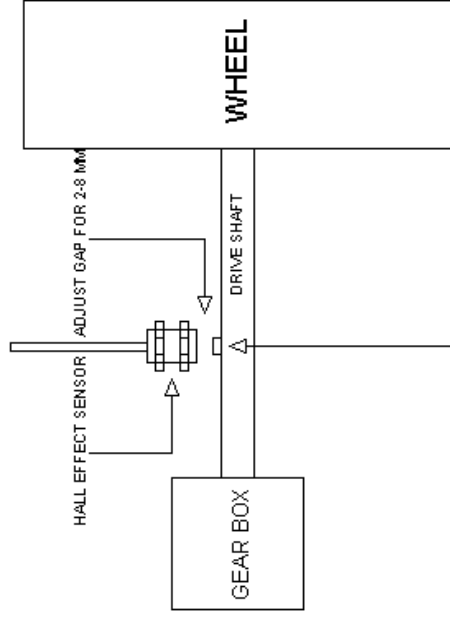

TYPICAL MOTORCYCLE INSTALLATION

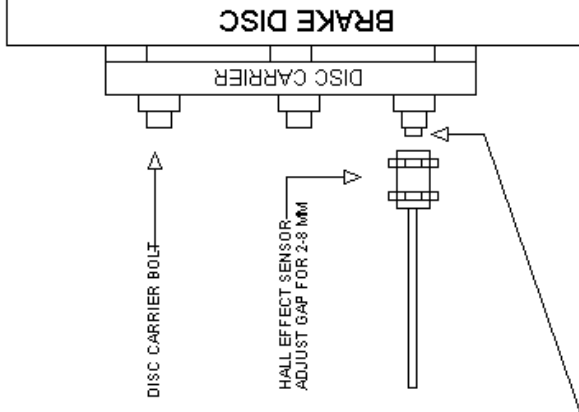

DISC MAGNET
GLUE WITH NORTH POLE
FACING DOWN* ON THE DRIVESHAFT
USE EPOXY GLUE TO FIX
EG ARALDITE OR PERMABOND.

* MARKED BY DIMPLE OR RED PAINT

PLEASE NOTE THAT ONLY ONE MAGNET
IS NOW NEEDED AND ONE IS SUPPLIED

A SUITABLE BRACKET WILL NEED TO BE MADE
FOR MOUNTING THE HALL EFFECT SENSOR.
THIS SHOULD BE MOUNTED ON A NON MOVING
MEMBER.