

SPA Stepper Motor Analogue pressure Gauge

Switch on the ignition to power on the gauge and watch the needle drive forward and then quickly back to the LED lamp, the needle will now move to show pressure. Press the button to recall maximum stored pressure. If you press and hold the button for more than 5 seconds, the stored maximum will be reset to zero.

When the vehicle lights are switched on, the gauge will use the night time brightness instead of the normal daytime brightness. Night time brightness can be set* from 0 to 100% brightness as desired. When the pressure falls below 25 psi, then the Red alarm LED will flash. This is also configurable* to any desired pressure. When the ignition is switched off, the gauge will park the needle back to zero and switch itself off.

*using the menu system:-

The menu system uses the major division of the dial scale to indicate menu item numbers.

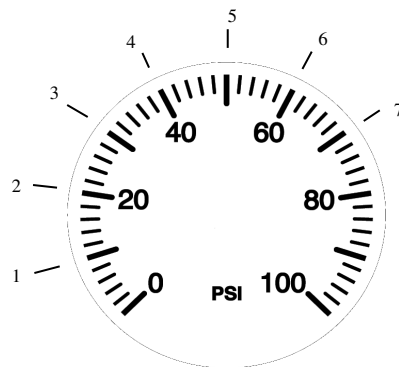

To access the menu system, switch the ignition off and wait for the gauge to switch off. Hold down the red button, and keep it down while you turn the ignition on. When the Red LED lights up, you are in the menu system and you can release the button. The needle is now pointing to menu item number 1. The LED lamp will light while pointing to a menu item number, and will go out when that menu item is accessed.

Menu items:-

- 1 - Demo mode: 0 = demo mode off, 1 = demo mode on
- 2 - Backlight brightness Night: 0 = off, full-scale = 100%
- 3 - Alarm set point: set to any pressure desired
- 4 - Zero sensor: zero the sensor at atmospheric pressure.
- 5 - Test sensor: shows the sensors voltage as 0-5v over the full scale.
- 6 - Averaging filter: Set higher to average out fluctuating pressure level.
- 7 - Exit menu: Return to normal gauge operation

Click the switch until the needle points the menu item number desired. Now press and hold down the button, and after 2 seconds the LED lamp will go out. The needle now shows the current setting for that menu item. Click or press and hold the button to change the setting, to return to the menu system wait for 4 seconds and the LED lamp will light and the needle will move to show the menu item number again. When you access menu item 7, the gauge will return to normal operation reading pressure.

Averaging filter: If a quick response is required, set this to a low value (default 2 clicks up from minimum).

Zero sensor: When you access this menu option, the LED lamp will go out and the needle goes to zero.

Hardware Installation

If the gauge is likely to be subject to extreme vibration, it should be mounted either in high density foam, or to a plate that is mounted on rubber bushes.

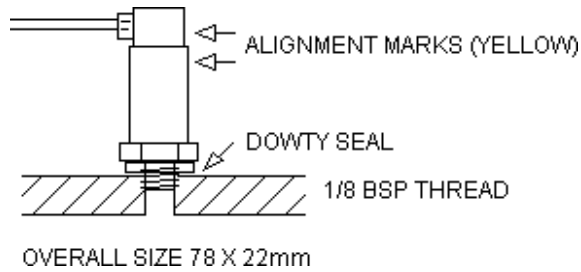
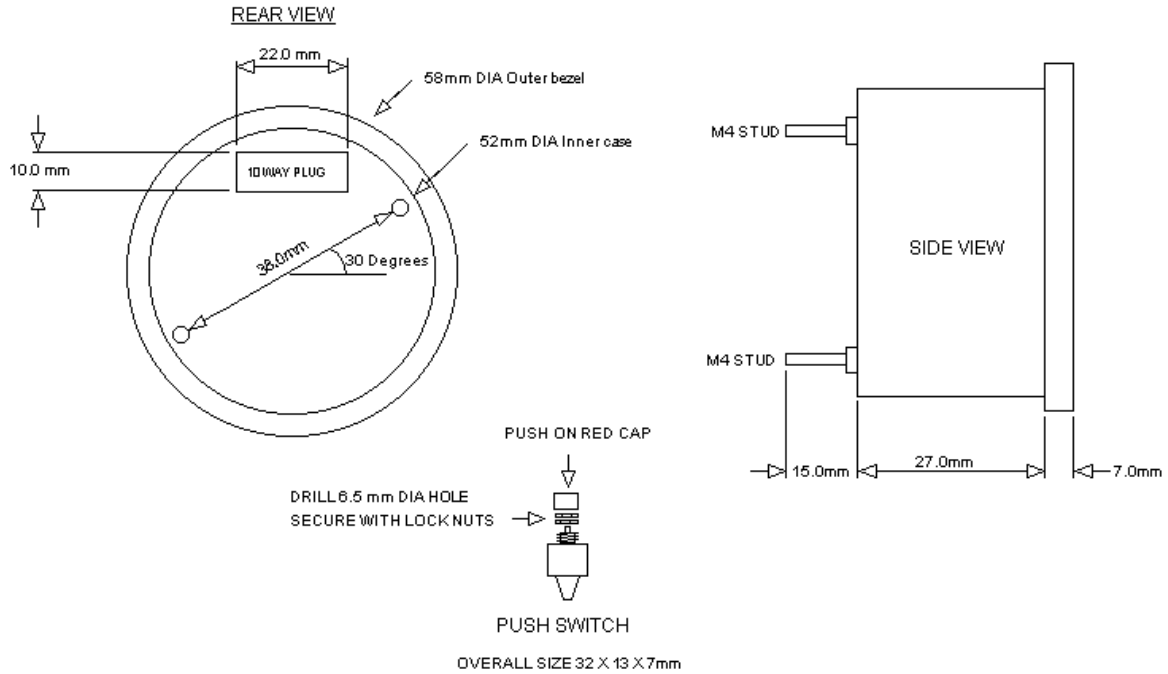

Electrical Installation

Wire the Red wire to a permanent (not switched) +12v connection.

Wire the Brown wire to +12v ignition feed, so it has +12v when the ignition is switched on.

Wire the Yellow/Green wire direct to chassis or a chassis spur.

Wire the black wire to lighting system, so it has +12v when the vehicle lights are switched on.

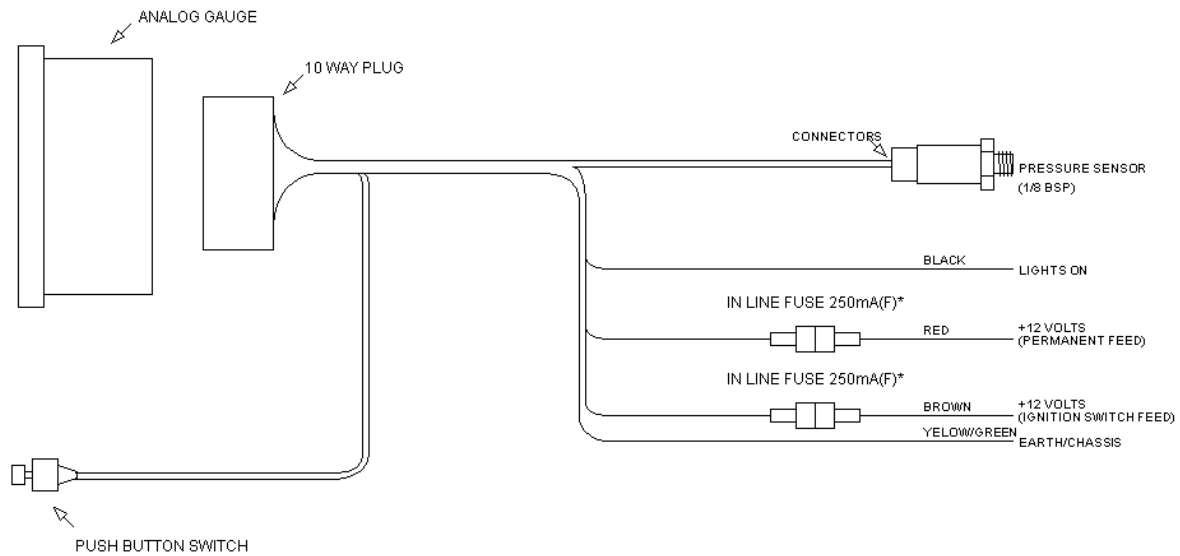

Specification:-

Supply Voltage: 12-16 volts (pulses allowed up to 28v)

Power consumption: 40mA typical

Accuracy: ~ 2%

Weight:

Size: 52mm DIA x 34mm (Bezel 58mm DIA)

Sensor thread: 1/8 BSP

Cable length: Temperature 2.7m, switch 60 cm

Absolute maximum ratings:-

Pressure sensor: 32 Bar / 464 PSI

Gauge: -20 to +70 degrees C